



HC3621FR

Ceramic Hob

Installation, Use and Maintenance

Important

The CDA Group Ltd cannot be held responsible for injuries or losses caused by incorrect use or installation of this product. Please note that CDA reserve the right to invalidate the guarantee supplied with this product following incorrect installation or misuse of the appliance or use in a commercial environment.

This appliance is not designed to be used by people (including children) with reduced physical, sensorial or mental capacity, or who lack experience or knowledge about it, unless they have had supervision or instructions on how to use the appliance by someone who is responsible for their safety.

Under no circumstances should any external covers be removed for servicing or maintenance except by suitably qualified personnel.

Appliance information:

Please enter the details on the appliance rating plate below for reference, to assist CDA Customer Care in the event of a fault with your appliance and to register your appliance for guarantee purposes.

Appliance Model	
Serial Number	

CE Declarations of Conformity

This appliance has been manufactured to the strictest standards and complies with all applicable legislation, including Electrical safety (LVD) 2006/95/EC and Electromagnetic interference compatibility

(EMC) 2004/108/EC. Parts intended to come into contact with food conform to 89/109/EC.

IMPORTANT INFORMATION FOR CORRECT DISPOSAL OF THE PRODUCT IN ACCORDANCE WITH EC DIRECTIVE 2002/96/EC.

At the end of its working life, the product must be taken to a special local authority waste collection centre or to a dealer providing appliance recycling services.

Disposing of a household appliance separately avoids possible negative consequences for the environment and health. It also enables the constituent materials to be recovered, saving both energy and resources. As a reminder of the need to dispose of household appliances separately, the product is marked with a crossed-out wheeled dustbin. 

Please note:

- Ceramic hobs become hot and remain hot during and immediately after use. Do not touch the hob until it has been allowed to cool.
- Keep children away from the appliance when in use.
- Never use the hob top for storage.
- Pan handles should never stand out beyond the edge of the worktop. This will help to avoid children reaching them.
- Do not lean over the hob when it is in use.
- Follow the cleaning instructions carefully.
- Ensure the base of the saucepan is clean and dry before placing it on the hob.
- Avoid hard shocks from cookware – the vitroc ceramic glass surface is highly resistant but not unbreakable.

-
- Do not place hot lids flat on the hob top. A “suction” effect could cause damage to the hob.
 - Do not drag cookware across the hob top: in the long term, this could cause damage to the hob.
 - Do not store cleaning or flammable products in the unit below the hob.
 - Always use appropriate cookware.
 - Do not cook unopened tins of food directly on the hob.
 - Never put cooking foil or plastic materials on the ceramic surface when the hob is hot. These materials could melt and cause damage to the hob.
 - This hob (Class 3) has been designed for use only as a cooking appliance. Any other use should be considered incorrect and therefore dangerous.

Important

- Do not use the hob if the glass surface is cracked or damaged to prevent the risk of electric shock. Disconnect it from the power supply.
- Ensure that the power cable of a connected electrical appliance near the hob is not in contact with the cooking zones.

Please note: When connecting the hob to the power and switching it on for the first time the cooking zone displays may show the letter "**H**". This is not a fault and the letter "**H**" should disappear after approximately one hour. Please see page 11 for more information.

Using your hob

Zones:

1. Front 1.2kW
Ø 145mm
2. Rear 1.8kW
Ø 180mm

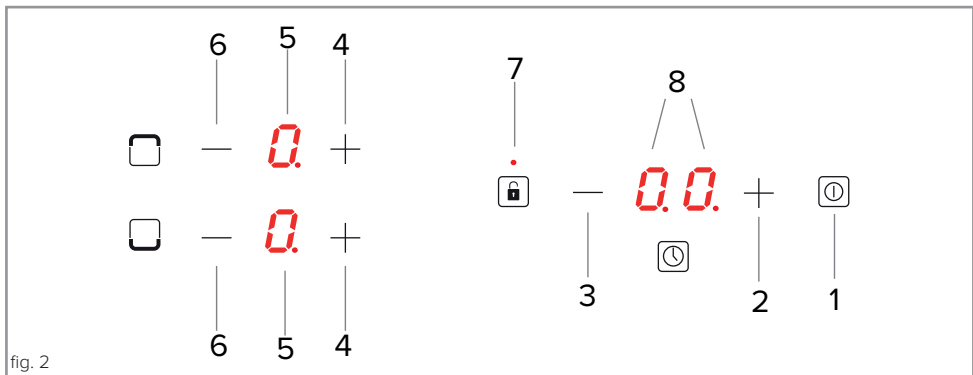
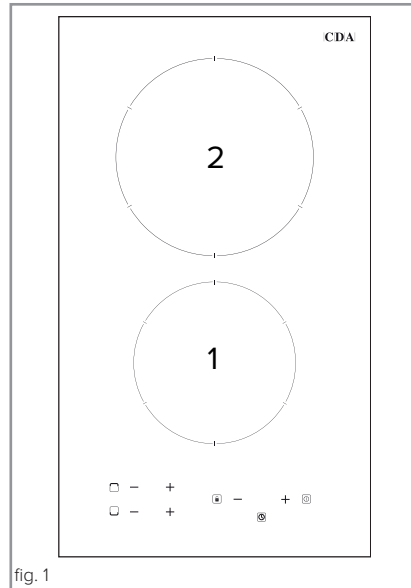

Control panel:

- | | |
|---------------------------------|-----------------------------------|
| 1. On/off sensor | 5. Cooking zone indicators |
| 2. Timer plus setting selector | 6. Zone minus setting selectors |
| 3. Timer minus setting selector | 7. Safety key lock sensor and LED |
| 4. Zone plus setting selectors | 8. Timer display |

Using Your Hob

To switch the hob on

- To switch the power on, touch and hold the "On/off sensor" (1) ① for approximately one second. The hob will beep and both cooking zone indicators (5) will show "0".

Please note: When switching the hob on after the appliance has been switched off at the mains, the front zone's display may show, in series, 4 0 3 and then the safety key lock will activate. This is normal. Simply press and hold the safety key lock sensor for approximately 2 seconds to disengage the lock and continue with normal operation.

To activate a zone and set a power level

- Simply switch the hob on and use the zone plus or minus setting selectors to set the desired power level. The power levels range from 1 (minimum) to 9 (maximum). The hob will then begin heating.

Please note: If a power level is not set within ten seconds of switching the hob on, the hob will switch off automatically.

To deactivate a zone

- Simply touch the zone's plus and minus setting selectors simultaneously. Alternatively, you can use the zone minus setting selector (6) to return the power level to 0. The cooking zone indicator will display a "0" to confirm that the zone is now inactive.
- If switching off both zones, the above step needs to be taken for each zone. When both the zones are at "0", the hob will switch off automatically after approximately ten seconds.

- To switch off the hob immediately, touch and hold the "On/off sensor" (1) for approximately one second.

Please note: Any zones that are still hot to the touch will display an "H" provided the mains power supply is not interrupted.

Operating time limiter

Each zone has an operating time limiter to increase overall efficiency and to prevent the hob from being left on indefinitely. If a zone's heat setting is not changed for a specific duration then the associated zone is automatically switched off and residual heat indicator activated. Zones can still be used as normal in accordance with the operating instructions. The operating time limiter is set according to the last selected heat setting. The maximum operating times for each setting can be found below.

Zone Power Level	1	2	3	4	5	6	7	8	9
Maximum Operating Time (hours)	10	5	5	4	3	2	2	2	1

Auto-heat Function

Both zones are equipped with an auto-heat function, which reduces the warming up time for the zone.

To activate the auto-heat function on a zone

- Switch the hob on, if not already so, and touch the zone's minus setting selector (6). Then, touch the zone's plus setting selector (4) and then set the desired power level using the zone's minus setting selector (6). A decimal point will appear next to the power level to confirm that the auto-heat function is active.

To deactivate the auto-heat function

- Simply touch the desired zone's minus setting selector (6). The decimal point next to the power level should display to confirm that the auto-heat function has been deactivated.

Each power level has a limited time for which the auto-heat function can be used. A table showing these times is shown below.

Zone Power Level	1	2	3	4	5	6	7	8	9
Maximum Operating Time (minutes)	1	2.4	4.4	5.2	6.2	1	2.4	2.4	--

Please note: The auto-heat function is not compatible with power level 9.

Timer

The hob is equipped with a timer that allows a finish time to be set for the end of cooking on any zone, between a minimum of 1 minute and a maximum of 99 minutes. The timer can only be used on one zone at a time. Once the timer is set, the timer display will show the time remaining. In normal use, the timer ending prompts the zone heating to end as well.

Please note: At the end of the timer, the selected zone's power will switch off and the timer display will flash. The hob will beep for approximately two minutes. To switch off the beep and the flashing display, touch any key.

To set the timer

- First switch on the hob if necessary and touch either the timer plus setting selector (2) or the timer minus setting selector (3).
- With the timer display pulsating, set the desired zone's power level.
- Next, touch the timer plus setting selector (2) and use this (and the timer minus setting selector if necessary) to set the number of minutes.
- The selection will confirm and the time will begin counting down. The relevant cooking zone indicator (5) will alternate between the set power level and the letter 't'.
- If no time is set within approximately five seconds, the timer display (8) will become inactive and the zone will continue cooking at the set power level.

Please note: The timer duration can be adjusted at any time during

the countdown. Simply touch the timer plus or minus setting selectors and re-adjust to the desired number of minutes.

To cancel the timer

- Simply touch the timer plus setting selector (2) and the timer minus setting selector (3) simultaneously. The timer display will revert to displaying '00' and after approximately 5 seconds the display will extinguish.

Safety Key Lock

To prevent accidental use, the hob has a safety key lock which switches controls off temporarily or completely. The safety key lock can be activated when the hob is turned on but not when power has been switched off at, or the appliance disconnected from, the mains. The safety key lock is automatically activated after mains power supply has been restored.

To activate the safety key lock

If the hob is off, then simply touch the safety key lock sensor (7) for approximately 2 seconds. The hob will beep and the safety key lock LED should illuminate. If the hob is on, then at least one zone needs to have a power level set for the safety key lock to work. With either one or both zones actively heating, press and hold the safety key lock sensor (7) for approximately 2 seconds. The hob will beep and the safety key lock LED should illuminate.

To deactivate the safety key lock

Simply touch and hold the safety key lock sensor (7) for approximately 2 seconds. The hob will beep and the safety key lock LED should extinguish.

Residual Heat Indicators

The hob is equipped with residual heat indicators to warn when any of the zones are still hot to the touch after use. An “**H**” will show on the relevant zone’s indicator for some time after cooking. You should avoid touching any zone whilst the hob is in use or whilst either residual heat indicator is displayed.

The duration for which the residual heat indicators are displayed is based upon the power level that has been used and the duration for which it was in use. As such, even after the residual heat indicator has extinguished, the hob may still be hot to the touch.

Please note: In the event of a power cut or failure, the residual heat indicators will illuminate after the power supply is restored. In the event of the restoration of the power supply, or when the hob is first installed and switched on, the hob assumes that the highest power level has been used for the longest time. As such, the residual heat indicators can show for up to one hour. This does not affect the hob’s operation and is not indicative of a fault. When there is no power supply to the hob however the residual heat indicators will not work, yet the hob zone(s) may still be hot, so extra care must be taken.

Efficient Use of Your Hob

The hob is equipped with zones designed to accommodate most shapes and sizes of pan. For best results, only use pans with flat bottoms. The most efficient use of the hob is shown below, where the pan and zone are correctly chosen. Use pan lids where possible to minimize the energy usage of your appliance.

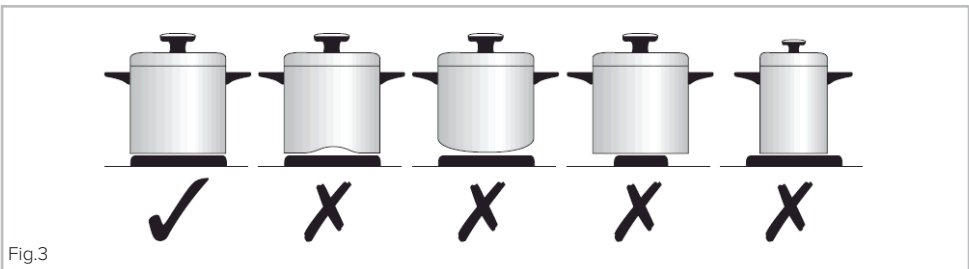

Zone Size	Minimum Pan Size (mm)	Maximum Pan Size (mm)
Ø 145mm	120	160
Ø 180mm	160	200

Locating a pan in the centre of the zone markings will ensure optimum efficiency.

It is very important that the pans used on the hob are made of a suitable material and have the correct type of base. The base of the pan and the hob top must be clean before use to prevent any scratches on the hob top.

Please note: Extra care should be taken if cast iron pans are used as these have coarse bases which may damage the hob top.

Care and Maintenance

Always disconnect the appliance from the power supply before undertaking any cleaning or maintenance.

Important:

- Steam cleaners must not be used when cleaning this appliance.
- You should use a non-abrasive cleaner to clean the hob top. Any abrasive cleaner (including Cif) will scratch the surface and could erase the control panel markings.
- Sugar and starch can cause permanent damage to the surface of the hob. Wipe away any spillages immediately but be careful given that the hob top will be hot during and after usage.
- Avoid letting pans boil over where possible to ensure that the need for cleaning is minimal.
- Always use a soft sponge or cloth where possible. Utensils such as scouring sponges and some brushes could cause scratches to the hob top.

A cleaning guide is available on page 14.

Type of residue	Clean with	Cleaning advice
Light	Cleaning sponge and soft cloth	Wipe over the zone to be cleaned with a sponge and hot water, and then wipe off with a soft dry cloth.
Accumulated baked-on stains/dirt, sugar spills or melted plastics	Cleaning sponge or glass scraper and soft cloth	Wipe over the zone to be cleaned with a sponge and hot water, using a ceramic scraper to remove any large marks or stains and then wipe off with a soft dry cloth.
Rings and hard water residues	White vinegar and soft cloth	Pour a small amount of warm white vinegar onto the stain, leave it to stand, and then wipe off with a soft dry cloth.
Shiny metallic streaks	Cleaning agent for vitroc ceramic glass	Use specialist vitroc ceramic glass cleaner (preferably one with silicone for its protective properties)

If your hob is not working:

1. Check that the zone is switched on.
2. Check that the mains supply has not been switched off.
3. Check that the fuse in the spur has not blown.

In the event of a fault with the hob please advise CDA Customer Care.

Contact CDA Customer Care

A: Customer Care Department, The CDA Group Ltd, Harby Road,
Langar, Nottinghamshire, NG13 9HY

T: 01949 862 012 F: 01949 862 003

E: customer.care@cda.eu W: www.cda.eu

Troubleshooting

Problem	Possible Causes	Possible Remedy
The appliance does not work and no indicators are lit.	The appliance has no power	Check the fuse and replace if blown.
Sensor fields do not respond when touched.	Appliance is not turned on	Turn on the appliance
	A sensor field has been touched too briefly (less than a second)	Touch the sensor field again and for longer
	Multiple sensors have been touched/covered at the same time	Only touch one sensor field at a time unless instructed otherwise
	The safety key lock is engaged	Disengage the safety key lock as per pages 10-11
The appliance does not respond and emits an extended beep	Improper use (wrong sensor fields touched or touched too briefly)	Switch the appliance off via the on/off sensor and at the mains and then switch the power and appliance on again
The appliance switches itself off	No heat level has been set within 10 seconds of activating the appliance	Switch on the appliance and set zone and heat setting without delay
	Sensor fields covered or dirty	Uncover or clean the sensor fields
A cooking zone switches itself off and a residual heat indicator is shown.	Operating time limiter has activated.	Nothing (see page 7)
	Sensor fields covered or dirty	Uncover or clean the sensor fields
	Electronic components have overheated	Nothing. Allow appliance to cool.

Problem	Possible Causes	Possible Remedy
Residual heat indicator has extinguished despite zone(s) still being hot.	The appliance has no power or the residual heat timer has expired (page 11).	Check the fuse and replace if blown.
Hob top is broken, cracked and/or chipped.	Stop using the appliance immediately and switch the appliance off at the mains. Contact CDA Customer Care to arrange a repair (contact details on page 14).	
A fault has not been resolved by any suggested remedies or a fault code is displayed	Contact CDA Customer Care using the contact details on page 14 to arrange a service visit.	

Should any error code show on the zone displays, or the above steps not resolve an issue, please contact CDA Customer Care for assistance. Contact details are on page 14.

IMPORTANT - PLEASE NOTE: In the event of any breakage, crack or cracking – even minimal – of the vitroceramic glass, immediately disconnect your appliance to prevent a risk of electric shock and contact CDA Customer Care.

Fitting the Hob

Unpacking the hob:

Take care not to lose, drop or mishandle any parts.

Fitting position of the hob:

This appliance must be installed a minimum of 50mm from any back wall and a minimum of 55mm away from any adjacent vertical surfaces, e.g. a tall cupboard end panel. These dimensions are shown in Fig.8 on page 19.

Ventilation requirements:

This appliance must be installed to allow air to flow freely to the air intake and from the air outlet. An air gap of 20mm is recommended immediately below the hob. Failure to allow sufficient ventilation could cause problems with operation or damage to the hob and constitutes incorrect installation, which is not covered by the product's warranty (Figs. 4 and 5).

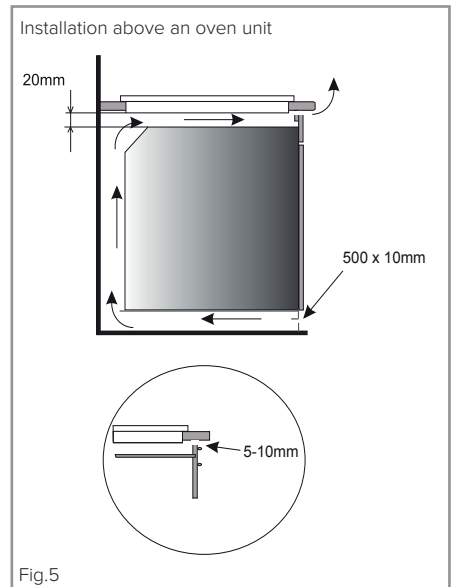
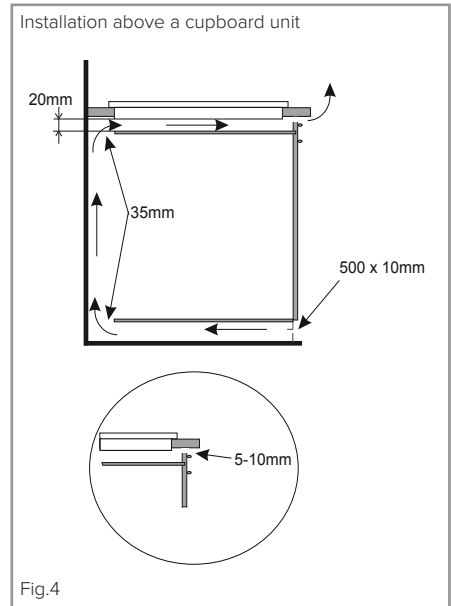

If fitting a cooker hood above the hob:

If a cooker hood is to be installed above the hob, the height of the hood above the hob must be at least 600mm (650mm is recommended) (Fig.6). If the instructions supplied with the hood dictate that the hood must be installed at a height greater than 600mm, then that height is the minimum required.

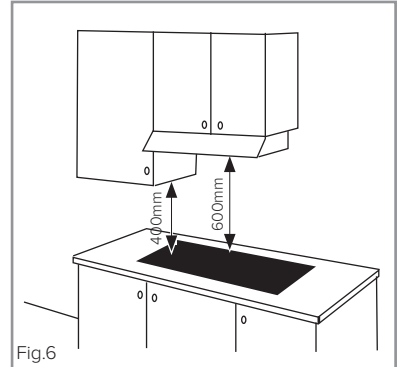

Wall furniture requirements:

The minimum height of any cabinet immediately above the hob is 900mm. The minimum height of any adjacent units (including light pelmets) is 400mm, unless they are manufactured from a material resistant to fire (steel, for example).

Important notes:

- Do not position this appliance above a refrigeration unit. The heat generated may cause the refrigeration unit to fail.
- This appliance is designed to be installed into cabinet units capable of withstanding temperatures of 65°C or greater above ambient temperature.
- Never place perishable foods, cleaning products or flammable items in the cupboard below the appliance.
- If the hob is to be located above a working drawer, we recommend that the drawer is not used for storing soft items, for example dusters or towels; this is to minimise the risk of the cooling system air intakes being obstructed.

How to Install the Hob

Overall dimensions of the hob:

Width: 300 mm Depth: 520 mm

Worktop cut-out dimensions:

Width: 285 mm Depth: 490 mm

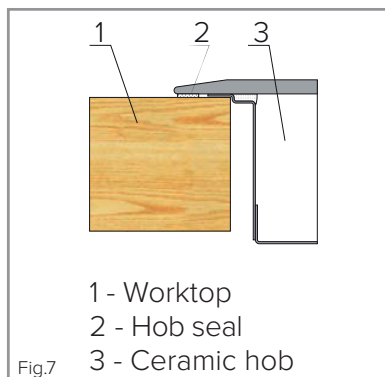

1. Make the required hole in the worktop.

Before doing this, you must check the

instructions supplied with any cooker hood to ensure that you will have the required clearance. The cut-out (Fig.8) shows a 60mm gap from the worktop edge to the cut-out edge. The distance from the hob, when fitted, to the back wall is to be 50mm.

If a splashback/worktop upstand is to be fitted, take this into account when cutting the hole. The minimum distance that the hob should be positioned away from the rear wall or splashback is 50mm.

2. Make sure that the worktop is clean and dust free and insert the hob into the cut-out opening. Press the hob firmly into place so that the seal connects with the worktop (Fig. 7).

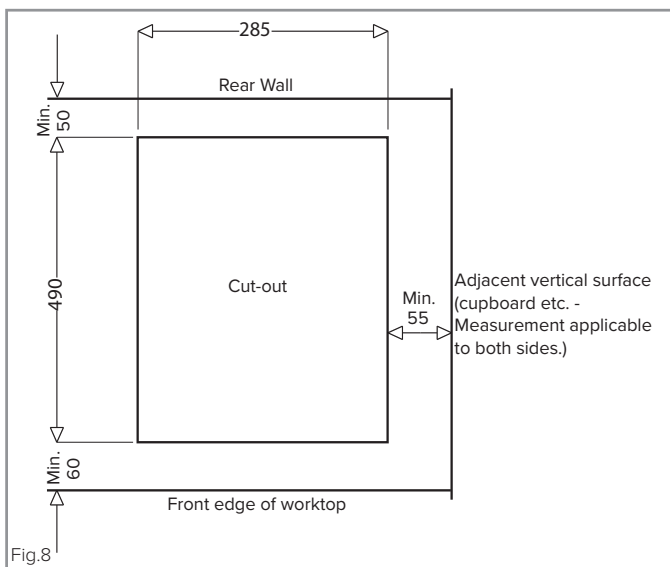

If fitting the hob into a 28-40mm worktop:

The four fixing clips supplied should be used. If fitting the hob into a thin worktop (i.e. 28mm), then we recommend using four 15x15x50mm wooden batons in addition to the brackets (as per figs. 9 and 10).

Position the fixing brackets perpendicularly to the hob's edge and tighten firmly.

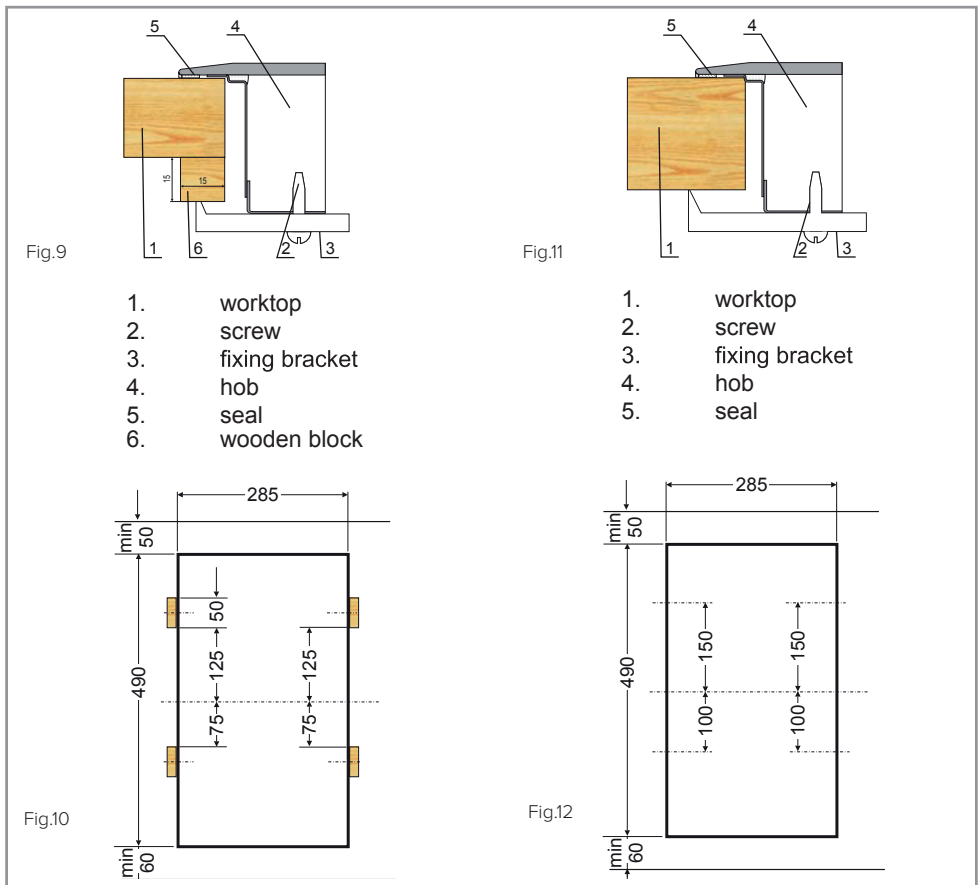

Mains Electricity Connection

Warning! This appliance must be earthed.

We recommend that the appliance is connected by a qualified electrician, who is a member of the N.I.C.E.I.C. and who will comply with the I.E.T. and local regulations.

This appliance is intended to be connected to fixed wiring and is not suitable for connection to a 13A plug.

This appliance is intended to be connected to fixed wiring by a double pole switch, having a contact separation of at least 3mm in all poles. The switch must be positioned no further than 2m from the appliance.

Please note:

- The mains cable must only be replaced by a qualified electrician or service engineer and must be of equivalent or better rating (i.e. 1.5mm², HO5VV-F).

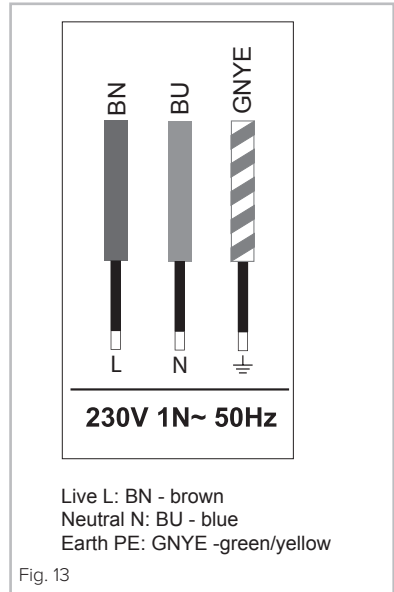

- This appliance is intended to be connected to the mains supply with a cable of cross sectional area 1.5mm².
- The current rating of the fuse or circuit breaker protecting this appliance should be marked on the socket outlet.
- Assembly and electrical connection should be carried out by specialised personnel.
- When installing this product we recommend you seek the help of another individual.
- **Should the mains cable be damaged or need to be replaced, it should only be done so by a qualified electrician or engineer. The connections to the hob are shown below;**

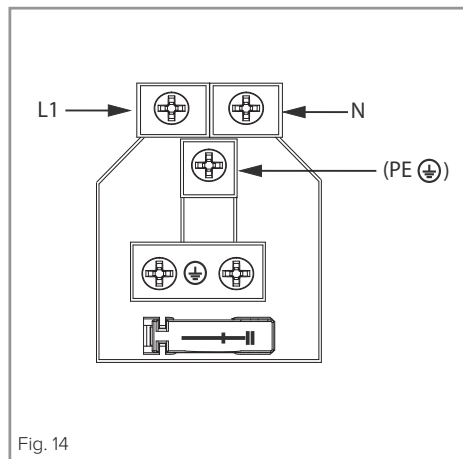

- Ensure that the leads are securely fitted. Failure to do so may prevent the hob from operating correctly.

Appliance electrical rating: 3000W

Energy Efficiency Information

Attribute	Symbol	Value	Units
CDA model		HC3621FR	
Type of hob		Built in	
Number of cooking zones and/or areas		2	
Heating technology (induction cooking zones and cooking areas, radiant cooking zones, solid plates)		Radiant cooking zones	
For circular cooking zones or area: diameter of useful surface area per electric heated cooking zone, rounded to the nearest 5mm	Ø	F:14.5 / R:18.0	cm
For non-circular cooking zones or areas: length and width of useful surface area per electric heated cooking zone or area, rounded to the nearest 5mm	L W	NA	cm
Energy consumption per cooking zone or area calculated per kg	EC <small>Electric cooking</small>	F:193.9 / R:193.9	Wh/kg
Energy consumption for the hob calculated per kg	EC <small>Electric hob</small>	193.9	Wh/kg

Please contact our **Customer Care Department** for Service on the details below

Customer Care Department

The ICDAI Group Ltd. • Harby Road • Langar • Nottinghamshire • NG13 9HY
T : 01949 862 012 F : 01949 862 003 E : customer.care@cda.eu

